



MANUAL – INSTALLATION

Linear Fan Terminal

Perimeter Series

v001 – Issue Date: 04/29/24

© 2024 Price Industries Limited. All rights reserved.

price | UNDERFLOOR

LINEAR FAN TERMINAL

TABLE OF CONTENTS

Product Overview

Introduction	1
General Safety Guidelines	1

Installation and Mounting Instructions

Flanged Plenum Installation	3
Flangeless Plenum Installation	3
Plenum with Leveling Feet Installation	4
Piping Multiple Units	5
Piping Configurations and PCM Control Wiring.....	5
Control Wiring Units	8
Price Controls Option	9
Design Parameters and Valve Options.....	11

LINEAR FAN TERMINAL

PRODUCT CONFIGURATIONS

Introduction

In this manual, you will find technical descriptions and diagrams of underfloor system components along with their installation instructions. Practical guidelines and recommendations are also provided. If more information is required about this equipment, please contact an Price sales representative.

National Wiring Code

Neutral - White

Ground - Green

Line - Black

General Safety Guidelines

This document is intended for use by owner-authorized operating/service personnel who are expected to possess the required training to enable them to perform their tasks properly and safely. This individual must have read and understood this document and any referenced materials prior to performing any task on this equipment. Also, it is essential that this individual be familiar with and comply with all applicable governmental standards and regulations pertaining to the task in question. This individual must also verify that installation and connections comply with local building codes. It is the obligation and responsibility of the operating/ service personnel to identify and recognize these inherent hazards, protect themselves, and proceed safely in completing their tasks. Failure to comply with any of these requirements could result in severe personal injury or death to themselves and people at the site, as well as serious damage to the equipment and the property in which it is situated.

The equipment discussed in this manual is relatively complicated apparatus and must be handled with the necessary precautions. Individuals may be exposed to certain components or conditions such as refrigerants, oils, materials under pressure, rotating components, and both high and low voltage during installation, operation, maintenance or service of this equipment. If misused or mishandled, each item has the potential to cause bodily injury or death.

Information in accordance with UL60335-1 and UL60335-2-40.

This unit can be used by children aged 8 years or more and also by people with reduced physical, sensory or mental capacities or a lack of experience and knowledge, if they are supervised or have been instructed in the safe use of the unit and the resulting dangers. Do not allow children to play with the unit. Do not allow children to clean the unit without supervision.

No user maintenance required.

LINEAR FAN TERMINAL

PRODUCT CONFIGURATIONS

FIGURE 1: LFT - ISOMETRIC “NON - FLANGED BORDER SHOWN” ▼

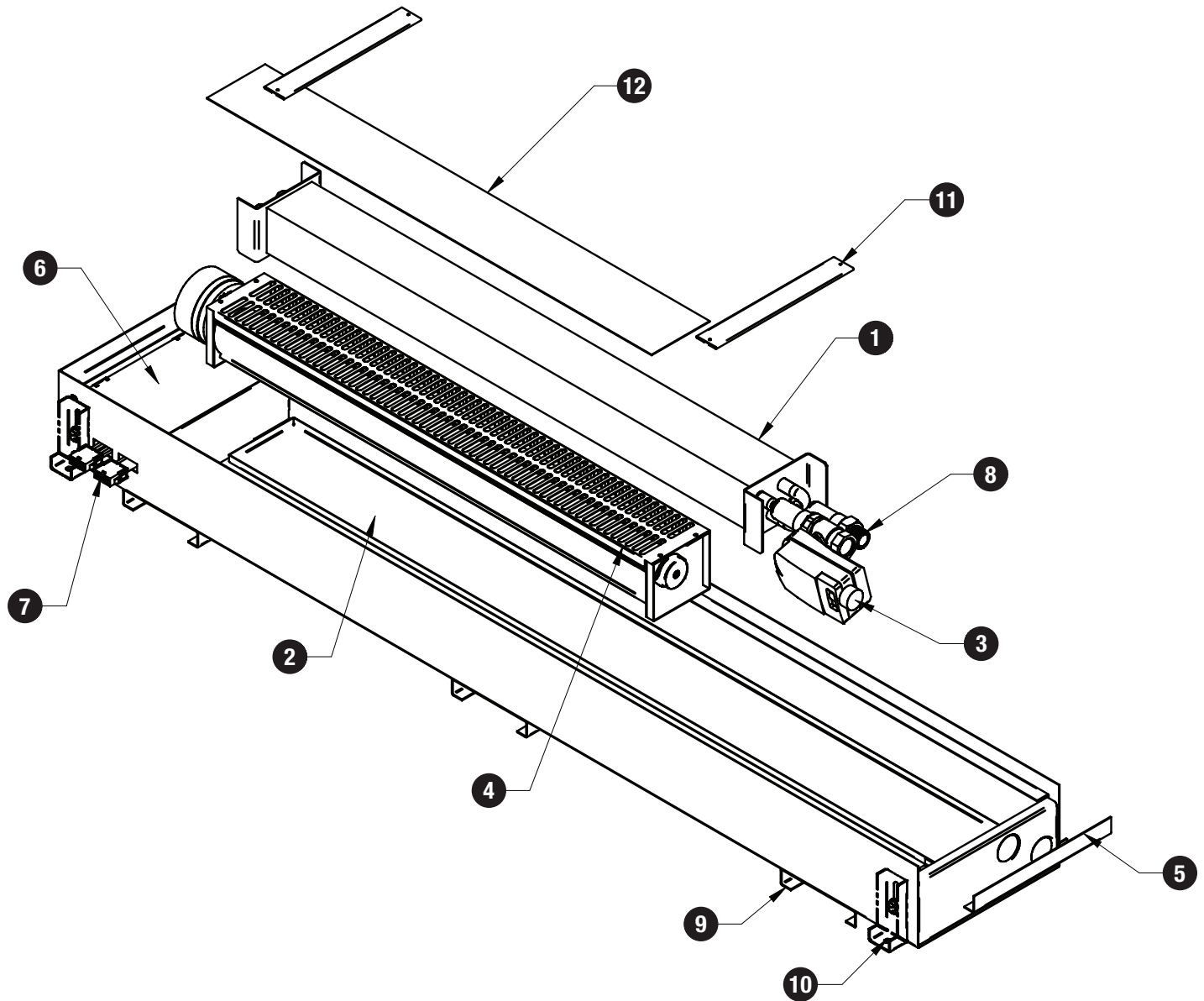

No.	Feature	No.	Feature
1	Water Coil	7	Power and Control Quick Connect (OPT)
2	Drain Pan or Drip Tray	8	NPT Water Connection (OPT)
3	Valve Actuator (OPT)	9	Pedestal Brackets (OPT)
4	24VDC Tangential Fan with Fan Cover	10	Leveling Feet (OPT)
5	Removeable Endcaps	11	Grille Support Bracket
6	Electrical Enclosure	12	Fan Filter (OPT)

LINEAR FAN TERMINAL

INSTALLATION & MOUNTING INSTRUCTIONS

Flanged Plenum Installation

1. The floor opening should be the same size as the nominal opening size used to order the floor plenum. See submittal for reference.

Optional: Install mounting angle (by others) along the perimeter wall if floor tile is not present on perimeter side. Angle should be installed at same height as finished floor. Install the first row of floor tiles maintaining the rough opening width.
2. Install plenum into floor opening with support flange resting above the tile. Ensure coil is located on perimeter side (see Figure 2).
3. Connect HW piping connections. Remove necessary knockouts for piping (see page 5).
4. Connect Quick Connect cable, if installing with Price controls.
5. Install LFG/RFG floor grille into plenum.

Flangeless Plenum Installation

1. The floor opening should be the same size as the nominal opening size used to order the floor plenum.
2. For pedestal supported units, install pedestal by sliding the pedestal head into the pedestal bracket before installing plenum into the floor opening with the coil located on the perimeter side. Ensure unit is level by adjusting pedestal height, and that pedestals are secured to the floor.

For the rest of the flangeless installation refer to steps 3-5 above. Additionally, install gaskets around the perimeter to prevent excessive air leakage (see Detail B).

Ensure units are flush with finished floor.

FIGURE 2: LFT FLOOR TILE SUPPORTED PLENUM SIDE VIEW ▼

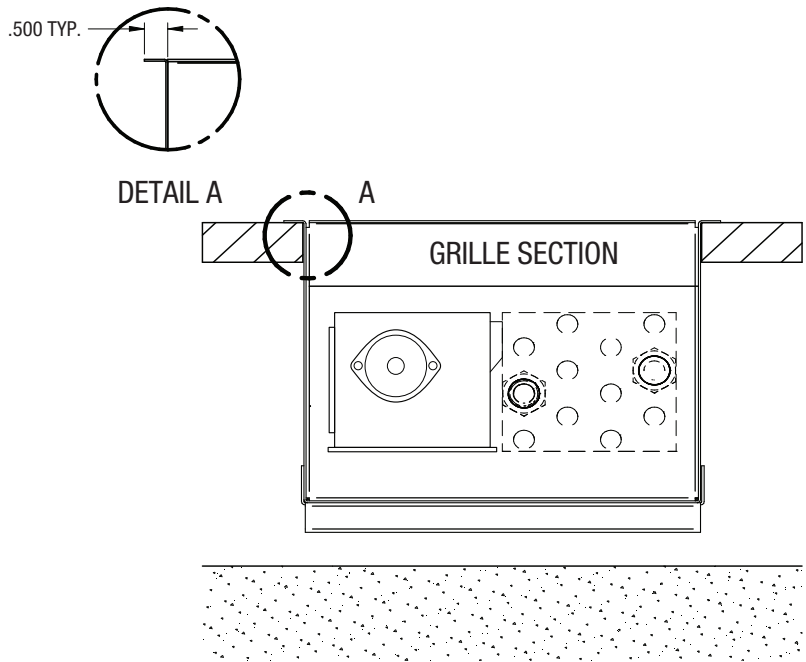
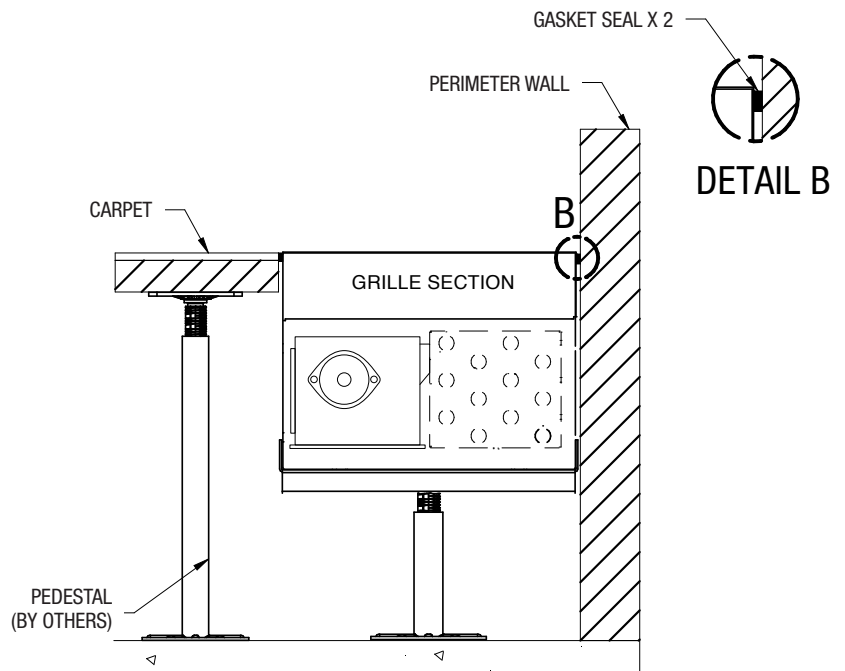

FIGURE 3: LFT NON-FLANGED PLENUM SIDE VIEW ▼



LINEAR FAN TERMINAL

INSTALLATION & MOUNTING INSTRUCTIONS

Plenum with Leveling Feet Installation

1. The floor opening should be the same size as the nominal opening size used to order the floor plenum.

NOTE: LFT units should be placed so that wall thermostats are not in direct path of the airflow.

NOTE: If applicable, ensure unit is a minimum of 8" away from obstacles such as curtains, furnitures, etc.

NOTE: Nominal Size (LXW) = Rough Floor Opening

2. For leveling feet supported units, install plenum into the floor opening. Ensure the coil is located along the perimeter side.
3. Adjust fastening screws internal to the unit to the desired height while simultaneously ensuring the unit is completely leveled.
4. Once the desired height and level has been achieved using the fastening screws, secure the height of the leveling feet along the outside of the plenum by using the machine screws.
5. Fasten the leveling feet to the floor.

FIGURE 4: LFT FLARED PLENUM SIDE VIEW ▼

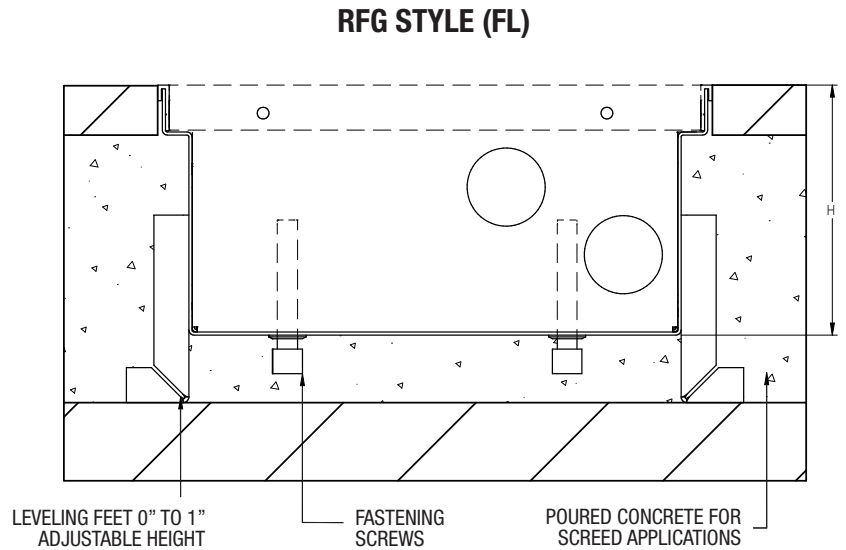

LINEAR FAN TERMINAL

INSTALLATION & MOUNTING INSTRUCTIONS

Piping Multiple Units

The units may be piped in a parallel configuration as shown in Figure 5 and in some cases units can be piped in series. Either configuration can be implemented to meet room design requirements.

For piping header configurations and knockout locations see below Figures 6-8.

FIGURE 5: LFTs IN PARALLEL CONFIGURATION

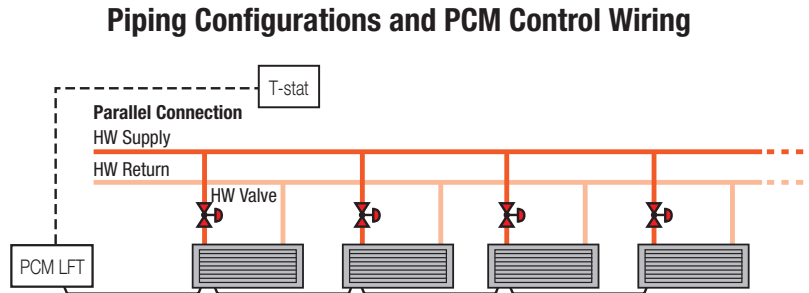
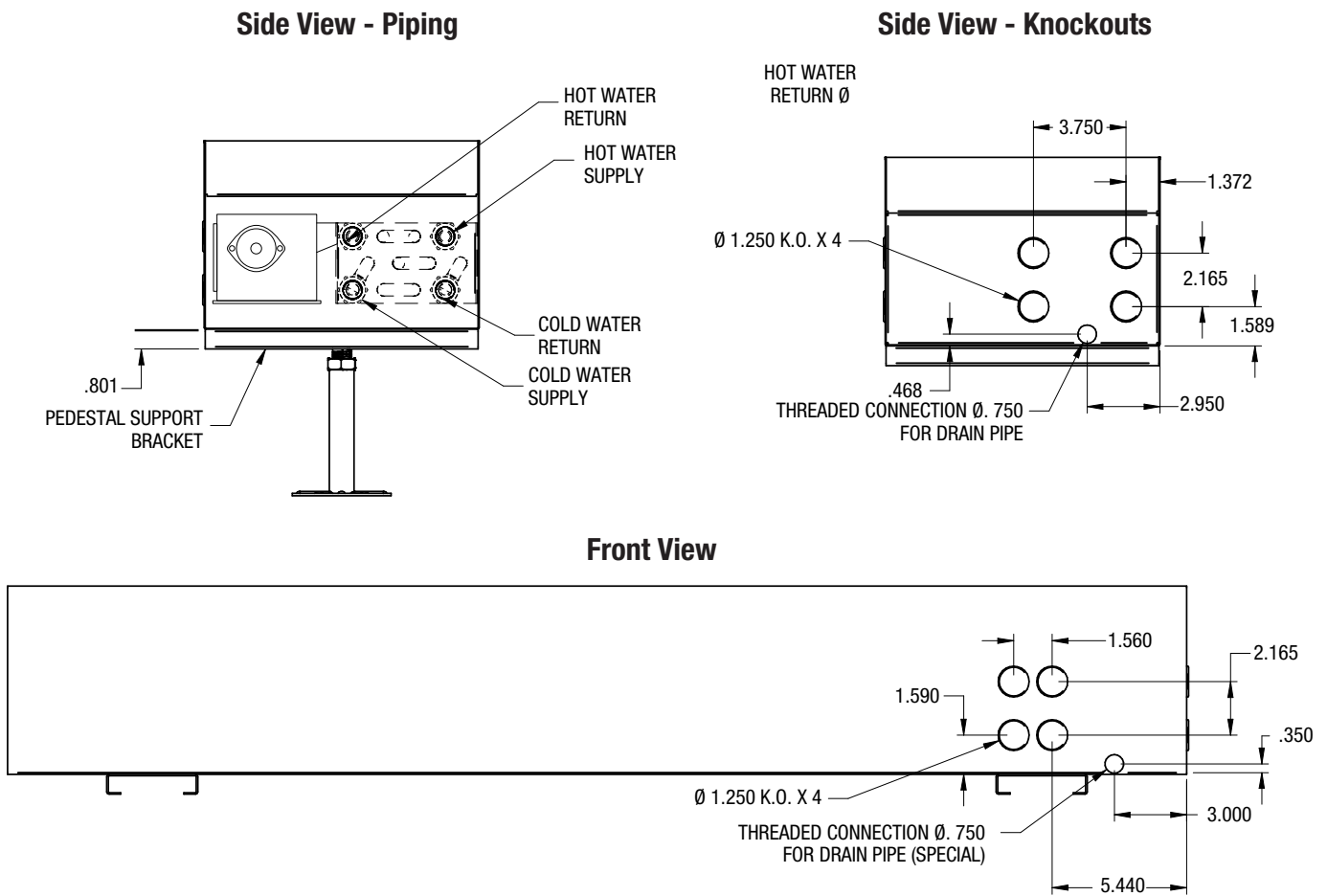

FIGURE 6: 4-PIPE HEADER CONFIGURATIONS AND KNOCKOUT LOCATIONS



LINEAR FAN TERMINAL

INSTALLATION & MOUNTING INSTRUCTIONS

FIGURE 7: LFT-HW WITH 2-PIPE 4 ROW WATER COIL ▼

Front View

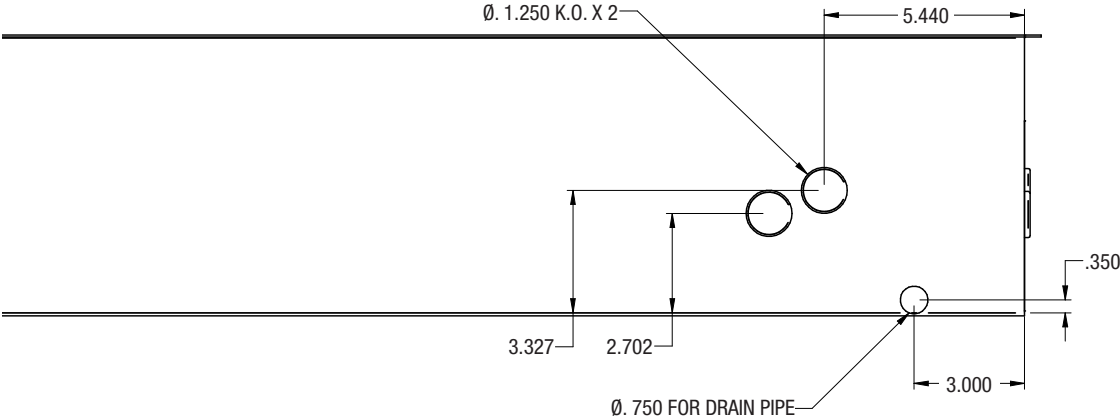

Side View

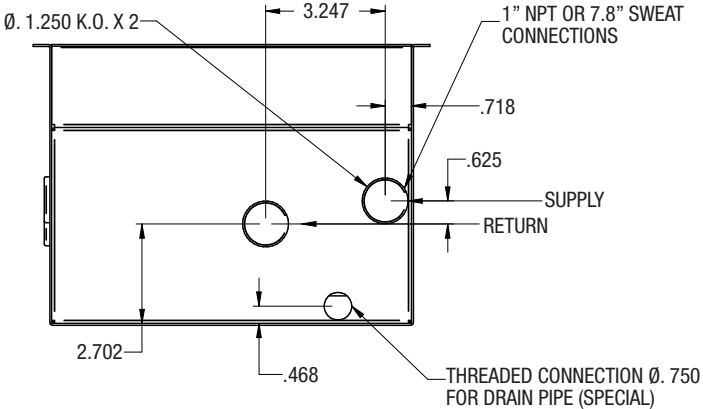

LINEAR FAN TERMINAL

INSTALLATION & MOUNTING INSTRUCTIONS

FIGURE 8: LFT-HW WITH 2-PIPE 2 ROW WATER COIL ▼

Front View

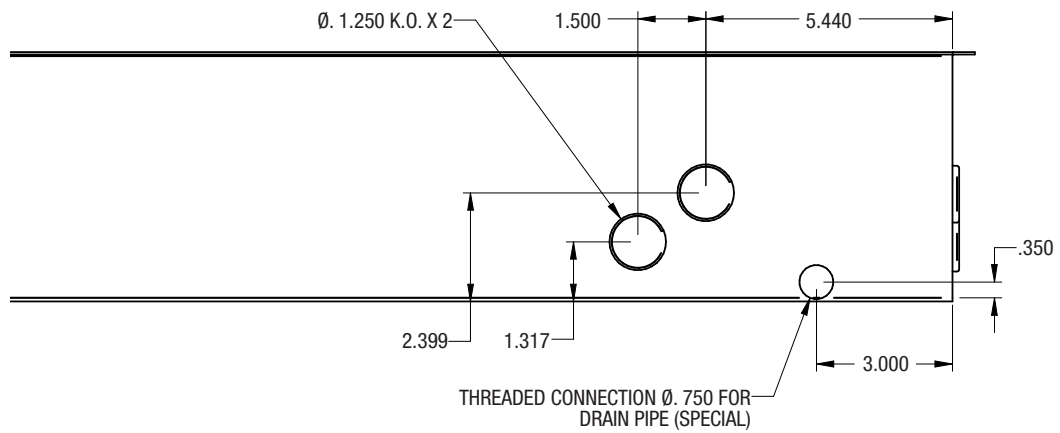

Side View

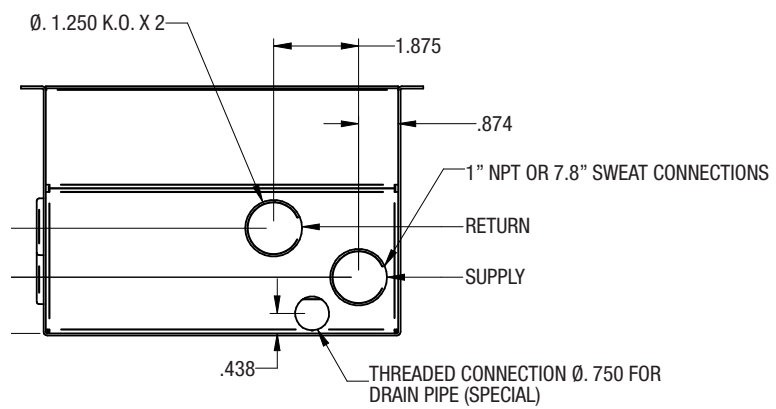

LINEAR FAN TERMINAL

INSTALLATION & MOUNTING INSTRUCTIONS

Control Wiring Units

Each PCM-LFT (ordered separately) controls a single zone in which all fans and heaters will operate in synchronization. Each linear fan terminal can be supplied with an optional plenum rated Quick Connect cable that allows all units to be plug-and-play daisy chained to each other and connect to the PCM-LFT. Refer to the PCM-LFT installation manual for more details.

FIGURE 9: CONTROL WIRING ▼

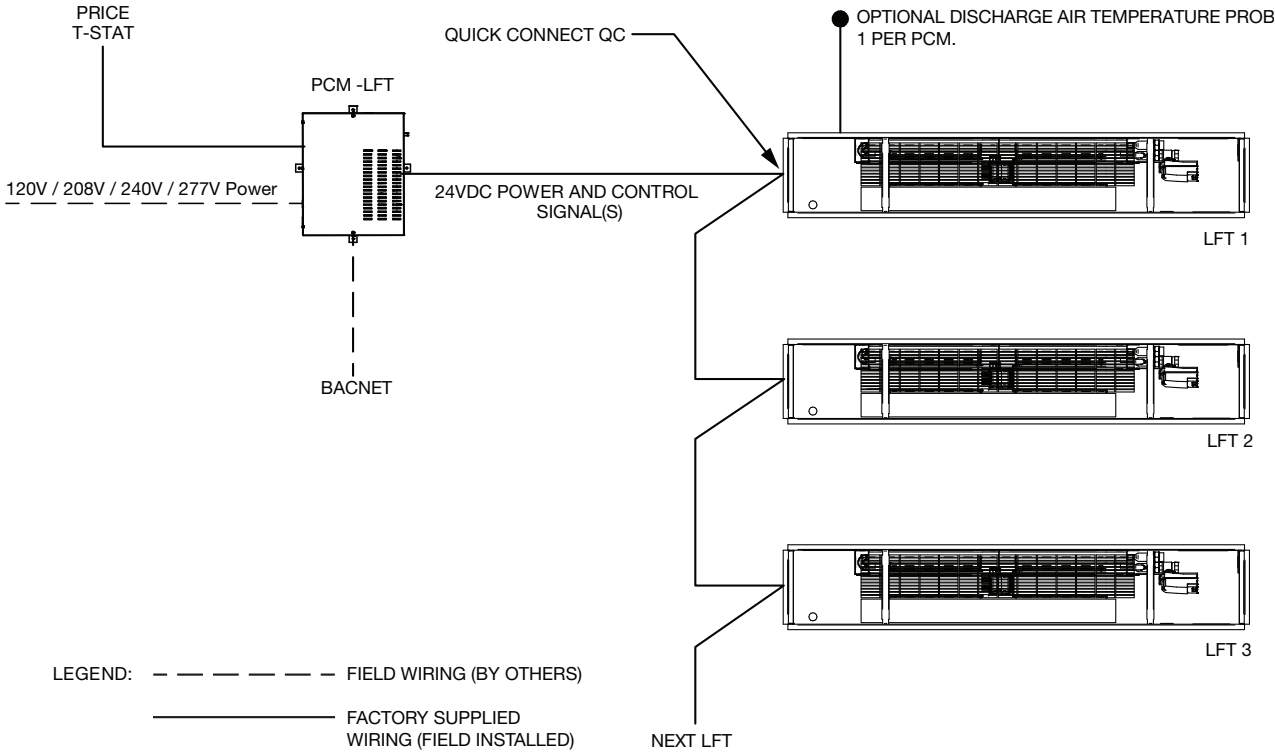

LINEAR FAN TERMINAL

INSTALLATION & MOUNTING INSTRUCTIONS

Control Wiring Units

Price Controls Option

A PCM-LFT controller may be wired to the HW valves to control the water delivered to the units in the space to meet design conditions.

FIGURE 10: LFT TERMINAL BLOCK WIRING ▼

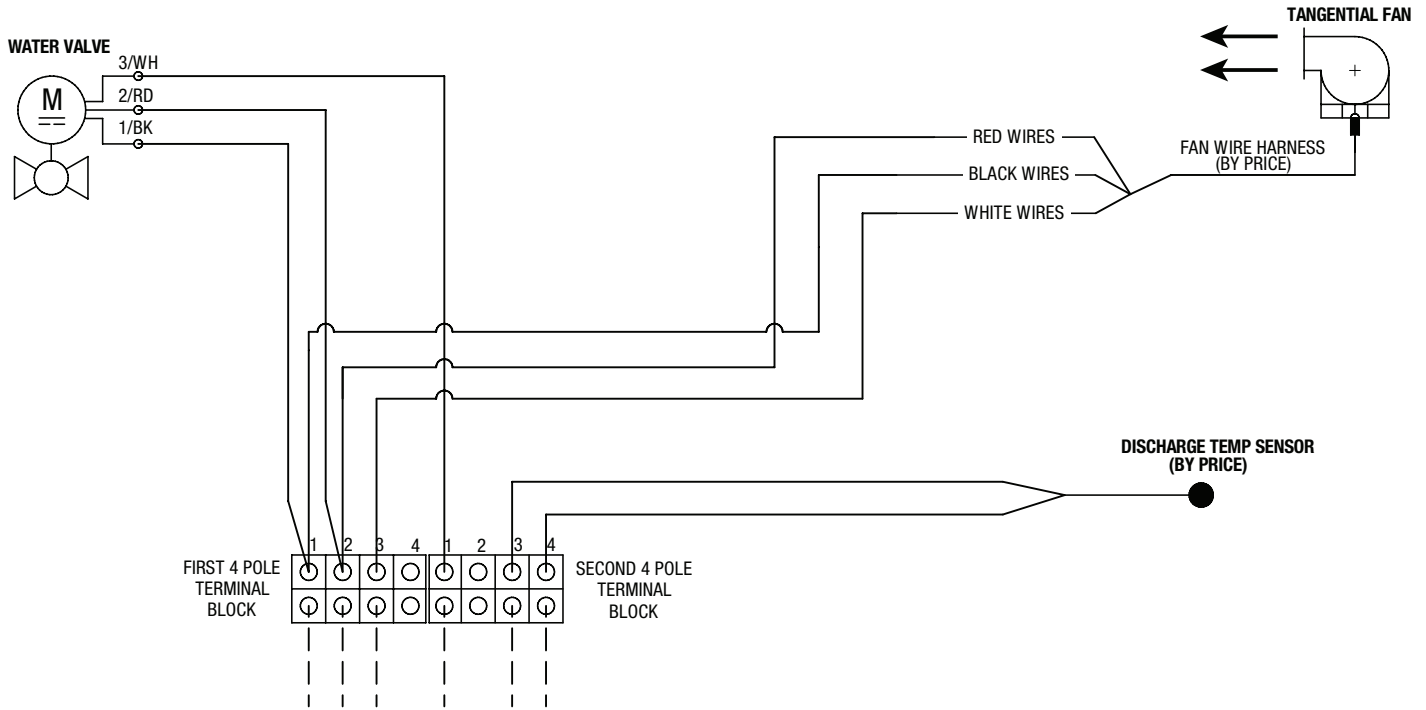

LEGEND - - - - - FIELD WIRING
 _____ FACTORY WIRING

FIRST 4 POLE TERMINAL BLOCK CONNECTIONS SCHEDULE	
POLE NUMBER	SIGNAL
1	24VDC NEGATIVE FROM POWER SUPPLY
2	24VDC POSITIVE FROM POWER SUPPLY
3	FAN SPEED 0-10VDC ANALOG OUT
4	N/A

SECOND 4 POLE TERMINAL BLOCK CONNECTIONS SCHEDULE	
POLE NUMBER	SIGNAL
1	2-10VDC TO WATER VALVE
2	N/A
3	DAT
4	DAT

LINEAR FAN TERMINAL

INSTALLATION & MOUNTING INSTRUCTIONS

FIGURE 11: LFT WIRING (ACTUATORS BY OTHERS) ▼

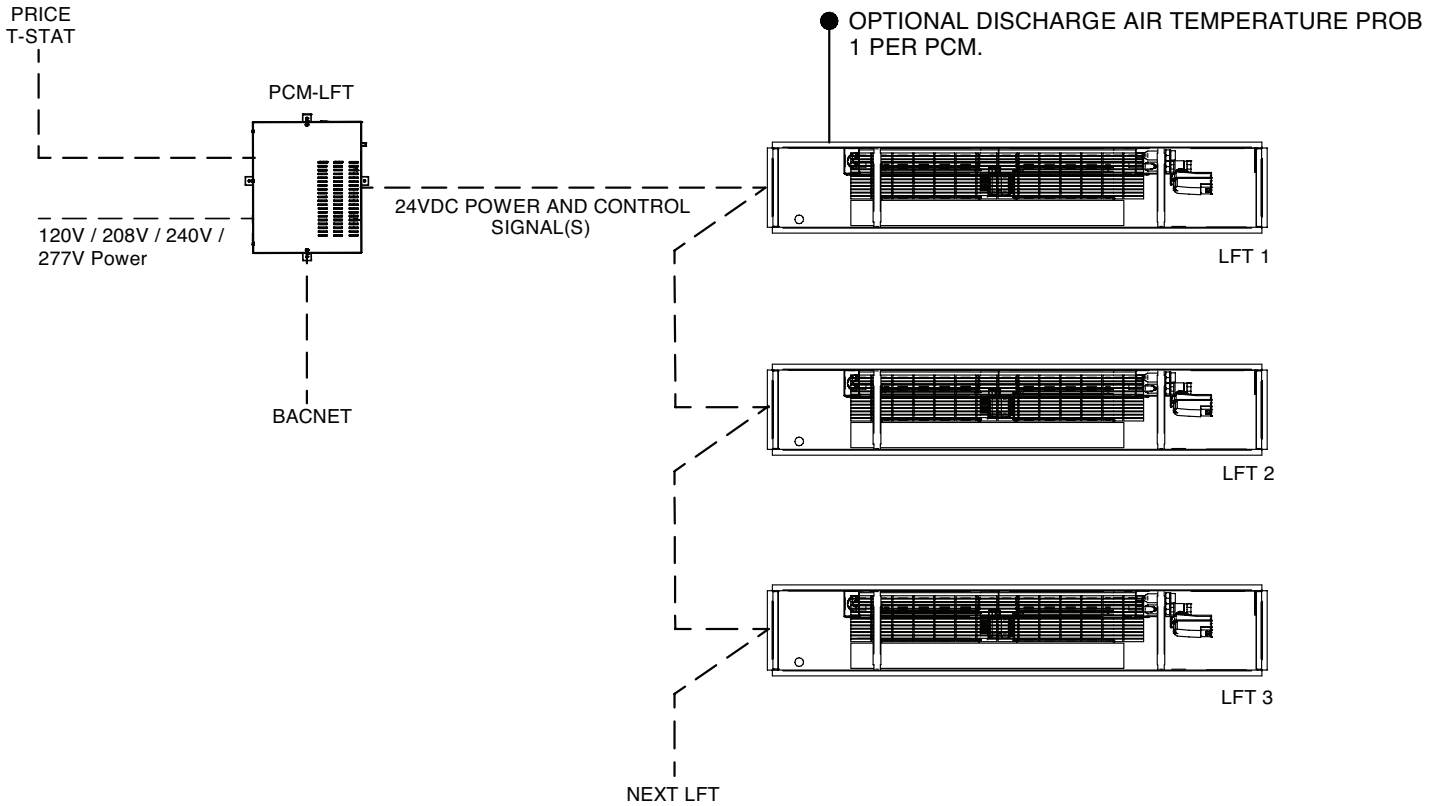

LEGEND: - - - - - FIELD WIRING
 _____ FACTORY WIRING

Nominal Plenum Dimensions (Rough Opening) for F and NF Style				Wattage (W)	AMPS (A) Fan Only
Height (H)	WC Type	Width (W)	Length (L)		
5.500 (140)*	2P 2R	8.000 (203)	48.000 (1219), 72.000 (1829), 96.000 (2438) 120.000 (3048)	19 W, 39 W, 46 W, 66 W	0.8 A, 1.7 A, 1.9 A, 2.8 A
7.625 (194)**	2P 2R	8.000 (203)	48.000 (1219), 72.000 (1829), 96.000 (2438) 120.000 (3048)	19 W, 39 W, 46 W, 66 W	0.8 A, 1.7 A, 1.9 A, 2.8 A
	2P 4R	10.000 (254)			
	4P 3R	11.250 (286)			

Nominal Plenum Dimensions (Rough Opening) for FL Style				Wattage (W)	AMPS (A) Fan Only
Height (H)	WC Type	Width (W)	Length (L)		
4.000 (102)*	2P 2R	9.000 (229)	48.000 (1219), 72.000 (1829), 96.000 (2438) 120.000 (3048)	19 W, 39 W, 46 W, 66 W	0.8 A, 1.7 A, 1.9 A, 2.8 A
6.125 (156)**	2P 2R	9.000 (229)	48.000 (1219), 72.000 (1829), 96.000 (2438) 120.000 (3048)	19 W, 39 W, 46 W, 66 W	0.8 A, 1.7 A, 1.9 A, 2.8 A
	2P 4R	11.000 (279)			
	4P 3R	12.250 (311)			

NOTES: * Comes with Drip Pan , ** Comes with Drain Pan

NOTE: Rated fan power is with no fan with no auxiliary load attached

LINEAR FAN TERMINAL

INSTALLATION & MOUNTING INSTRUCTIONS

Design Parameters and Valve Options

Design Parameters	Description	
Entering Water Temperature	Cooling	Heating
	42-58 (°F) / 5.5-14.4 (°C)	100-180 (°F) / 37.7-82.2 (°C)
Water Flow Rate	0.5-3.0 (GPM) / 0.03-0.19 (L/s)	
Maximum Operating Pressure	300 (PSI) / 2068 (kPa)	
Valve Actuators	Binary	Analog
	2-way, Non-fail-safe, AC/DC 24V, On/Off, Floating point/3-Point	2-way, Non-fail-safe, AC/DC 24V, 2-10V, Modulating

“This appliance incorporates an earth connection for functional purposes only.”

This document contains the most current product information as of this printing.
For the most up-to-date product information, please go to priceindustries.com

© 2024 Price Industries Limited. All rights reserved.

